

F-Series ITB

Integrated Actuator and Throttle Body (48, 60, 68 mm)

Applications

The F-Series ITB is designed to throttle air or air/fuel mixtures for gaseous engines in industrial and on-highway service. This system is designed for direct replacement of traditional throttle valves, and requires no linkage between valve and actuator. The ITB contains a return spring to fully comply with US DOT 571.124 specifications. The three sizes are designed to cover a wide range of engines, and should be selected using the sizing procedure described in this specification.

The F-Series ITB actuator software must be properly set up for the application. Refer to manual 26355 for detailed instructions.

Description

The F-Series Integrated Throttle Bodies (ITB) are butterfly valves electrically actuated by an F-Series actuator to control flow output. Flow is a function of inlet and outlet pressure, throttle size, and throttle position. Throttle position is proportional to the position demand. The actuator drives the 0–70 degree output shaft to the demanded position based on an internal shaft position sensor.

There are two ITB actuator types:

- F-Series Throttle (FST)
- F-Series Throttle Plus (FSTP)

Both the FST and FSTP actuators accept a PWM position demand signal while the FSTP can also accept a J1939 CAN, 4–20 mA or 0–5 Vdc position demand. An optional non-linear position demand curve can be configured for a non-linear actuator response versus the position demand input signal.

The CANbus protocol is SAE J1939.

A 0–5 Vdc configurable position feedback signal provides for monitoring throttle position and for possible feed-forward control. A sight cover is provided over the slotted throttle shaft end to view the actual throttle position. Note that the throttle plate is 15° off horizontal (flange plane) when the valve is fully closed.

The FSTP version includes a relay driver output that changes state whenever the controller detects a configured fault or error condition.

The FSTP version includes discrete inputs for a Run Enable/Key Switch and to set the CAN ID.

The F-Series actuator operates on 10–32 Vdc. The ambient operating temperature range is –40 to +105 °C (–40 to +221 °F).

The F-Series ITB is available in 48, 60, and 68 mm bore sizes. The throttle bodies provide maximum flow rates equivalent to standard throttle bodies of equal diameter. The ITB is designed to operate on air and gases ranging from pipeline quality natural gas to specialty gas (such as landfill, digester, or other biogases). The ITB alleviates the problems associated with linkages on gas engines (such as setup, non-linearity, and wear).

The direct combination of throttle and actuator results in excellent transient response and stability, and requires no hydraulics, pneumatics, or gear train. Therefore, you end up with an efficient, long lasting, and easily installed throttle option.



- No linkage or couplings
- Requires no hydraulics, pneumatics, or gear train
- Long lasting, small size, easy to install throttle option
- Includes return spring to fully comply with US DOT 571.124 specs
- Versatile 12 or 24 Vdc operation
- CAN communication (FSTP Only)
- Advanced diagnostics
- Models are available:
 - ✓ With certification for North American Hazardous Locations
 - ✓ Compliant with the applicable CE Directives – EMC, Pressure Equipment, Machinery
 - ✓ With Type Approval to UNECE Regulations 67 and 110

Determining the Proper Valve Size

The proper size valve can be determined using the equation below. The required Cv (flow coefficient) should be calculated for both the minimum and maximum flows expected on the application. This design allows for a nominal travel of 70 degrees of rotation.

Using the graph and table below, select the closest valve that has a Cv equal to or greater than the calculated maximum flow value at approximately 80% opening (55 degrees) to ensure reasonable flow margin. Also, check that the particular valve's minimum Cv listed below is less than the minimum calculated Cv for good low idle performance. For further assistance, consult the Woodward engineering department.

$$Cv = Q * .00978 * (G * T / ((P1-P2) * K)) ^ 0.5$$

Where:

Cv = Valve Flow Coefficient

Q = Flow (lb/h) (1 lb = 0.4536 kg)

G = Specific gravity of fluid (use 1.0 for air. & 0.6 for Nat Gas)

T = Absolute inlet temperature (460 + °F)

P1 = Inlet pressure (psia)

P2 = Discharge pressure (psia)

K = P2 if P1-P2 is less than 10% of P1

= P1 if P1-P2 is 25% or more of P1

= (P1+P2)/2 if P1-P2 is in between 10 and 25%

Note—P2 must be Greater than 0.528 * P1 (or flow becomes choked). If P2 is less than 0.528 * P1, then use P2= 0.528 * P1

F-Series Cv Curves

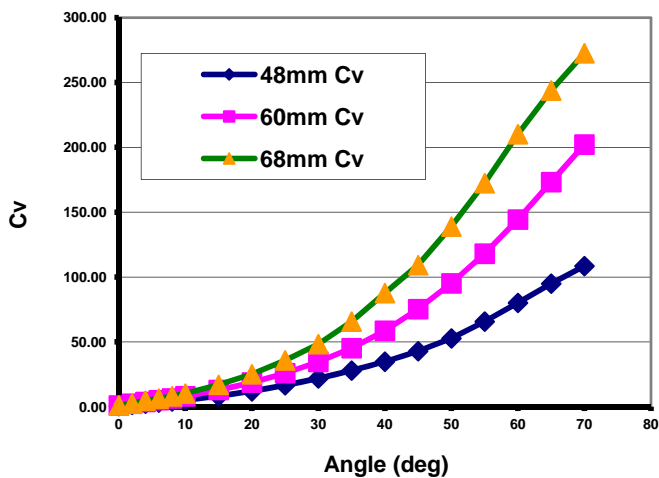

Position (Deg)	48 mm Cv	60 mm Cv	68 mm Cv
0	0.65	1.08	1.08
2	1.54	2.43	2.51
10	5.15	8.16	10.20
15	8.18	12.99	16.94
20	12.00	18.77	25.11
30	21.95	34.67	48.31
40	34.82	58.62	87.71
50	52.76	95.19	138.93
55	65.75	118.06	172.42
60	80.12	144.36	210.18
70	108.50	202.19	272.55

Cv (flow coefficient)

Description	AMP P/N	Woodward P/N
Mating Connector, 14-Pin	776273-1	1635-1517
Mating Connector, 23-Pin	770680-1	1751-805
Gold Sockets for all Connectors	770854-3	1608-1044

Note—These flow coefficients were determined using the test setup described in ANSI/ISA-S75.02-1996 "Control Valve Capacity Test Procedure"

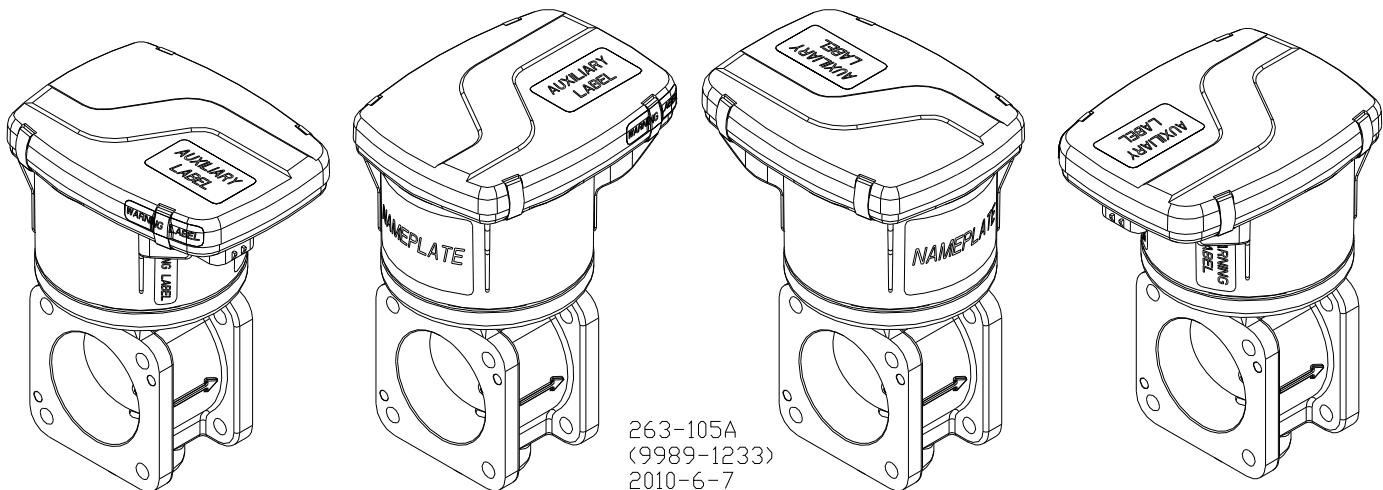

CONNECTOR PLAN A

CONNECTOR PLAN B

CONNECTOR PLAN C

CONNECTOR PLAN D

263-105A
(9989-1233)
2010-6-7

Electrical Connector Orientation Options

Installation

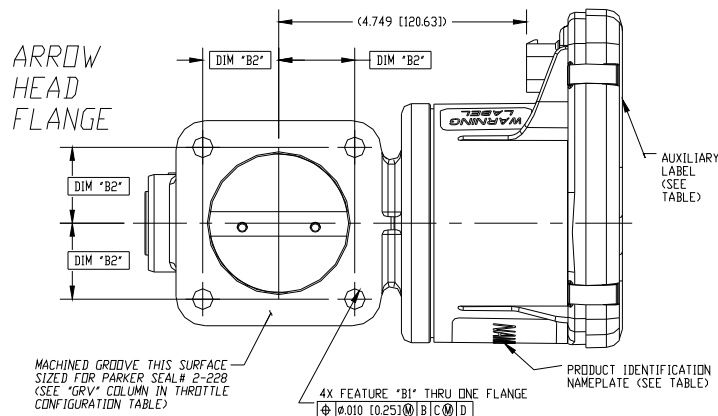
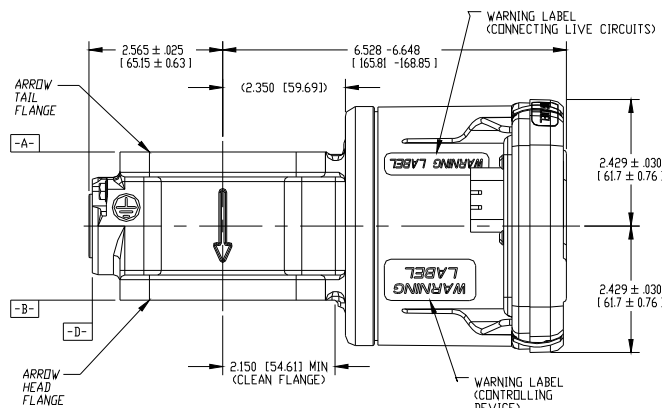
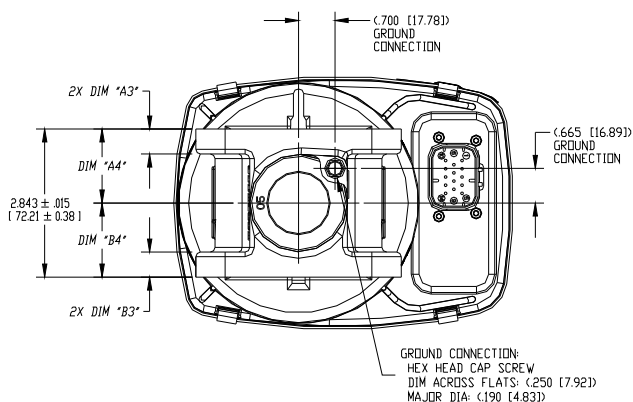
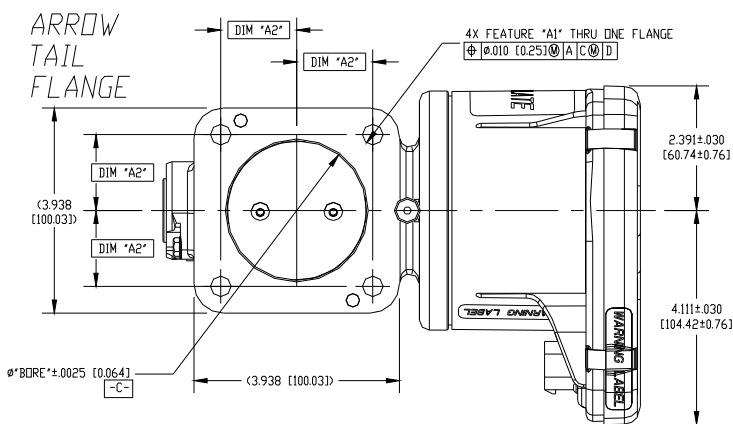
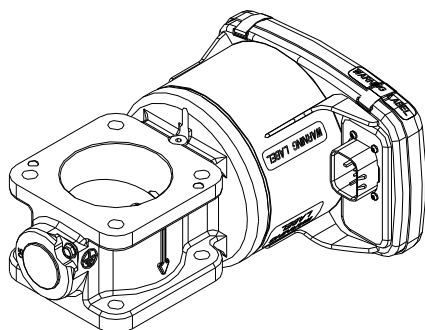

263-105B
(9989-1233)
2010-6-7

THROTTLE OPTION DETAILS										263-105C (9999-1233) 2010-6-7	
THROTTLE OPTION	BORE	DETAILS -- ARROW TAIL FLANGE				DETAILS -- ARROW HEAD FLANGE				THROTTLE DESCRIPTION (REFERENCE)	
		A1	A2	A3	A4	B1	B2	B	B4		
48/STD	1.8900 (48.006)	Ø394±.010 (10.01±0.25)	1.457 (37.01)	480±.060 (12.19±1.52)	(1.4215 (36.106))	Ø394±.010 (10.01±0.25)	1.457 (37.01)	480±.060 (12.19±1.52)	(1.4215 (36.106))	NO	48 MM BORE, THRU ØS FOR .375 SCREWS
48/M08	1.8900 (48.006)	Ø354±.010 (8.99±0.25)	1.339 (34.01)	480±.060 (12.19±1.52)	(1.4215 (36.106))	Ø354±.010 (8.99±0.25)	1.339 (34.01)	480±.060 (12.19±1.52)	(1.4215 (36.106))	YES	48 MM BORE, THRU ØS FOR M8 SCREWS, GROOVE USES PARKER 2-228
60/STD	2.3625 (60.008)	Ø394±.010 (10.01±0.25)	1.457 (37.01)	480±.060 (12.19±1.52)	(1.4215 (36.106))	Ø394±.010 (10.01±0.25)	1.457 (37.01)	480±.060 (12.19±1.52)	(1.4215 (36.106))	NO	60 MM BORE, THRU ØS FOR .375 SCREWS
60/JADE	2.3625 (60.008)	Ø354±.010 (8.99±0.25)	1.535 (38.99)	425±.060 (10.8±1.52)	(1.3665 (34.709))	M8X1.25 THD (34.709)	1.457 (37.01)	.535±.060 (13.59±1.52)	(1.4765 (37.503))	NO	60 MM BORE, THRU/THD'D ØS FOR M8 SCREWS
60/M10	2.3625 (60.008)	Ø453±.010 (11.51±0.25)	1.457 (37.01)	480±.060 (12.19±1.52)	(1.4215 (36.106))	Ø453±.010 (11.51±0.25)	1.457 (37.01)	480±.060 (12.19±1.52)	(1.4215 (36.106))	NO	60 MM BORE, THRU ØS FOR M10 SCREWS
68/STD	2.6800 (68.072)	Ø394±.010 (10.01±0.25)	1.457 (37.01)	480±.060 (12.19±1.52)	(1.4215 (36.106))	Ø394±.010 (10.01±0.25)	1.457 (37.01)	480±.060 (12.19±1.52)	(1.4215 (36.106))	NO	68 MM BORE, THRU ØS FOR .375 SCREWS
68/M10	2.6800 (68.072)	Ø453±.010 (11.51±0.25)	1.457 (37.01)	480±.060 (12.19±1.52)	(1.4215 (36.106))	Ø453±.010 (11.51±0.25)	1.457 (37.01)	480±.060 (12.19±1.52)	(1.4215 (36.106))	NO	68 MM BORE, THRU ØS FOR M10 SCREWS
33/STD	1.299 (32.995)	Ø394±.010 (10.01±0.25)	1.457 (37.01)	480±.060 (12.19±1.52)	(1.4215 (36.106))	Ø394±.010 (10.01±0.25)	1.457 (37.01)	480±.060 (12.19±1.52)	(1.4215 (36.106))	NO	33 MM BORE, THRU ØS FOR .375 SCREWS
75/STD	2.952 (74.981)	Ø413±.010 (10.49±0.25)	1.875 (47.62)	480±.060 (12.19±1.52)	(1.813 (46.050))	Ø413±.010 (10.49±0.25)	1.875 (47.62)	480±.060 (12.19±1.52)	(1.813 (46.050))	NO	75 MM BORE, THRU ØS FOR .375 SCREWS
60/SLOT	2.3625 (60.008)	Ø394±.010 (10.01±0.25)	1.457 (37.01)	480±.060 (12.19±1.52)	(1.4215 (36.106))	Ø515 X .375 SLOT	1.457 (37.01)	480±.060 (12.19±1.52)	(1.4215 (36.106))	NO	60 MM BORE, SLOT ON ARROW HEAD FLANGE.
68/SLOT	2.6800 (68.072)	Ø515 X .375 SLOT	1.457 (37.01)	480±.060 (12.19±1.52)	(1.4215 (36.106))	Ø394±.010 (10.01±0.25)	1.457 (37.01)	480±.060 (12.19±1.52)	(1.4215 (36.106))	NO	68 MM BORE, SLOT ON ARROW TAIL FLANGE.
60/SLOT	2.3625 (60.008)	Ø515 X .375 SLOT	1.457 (37.01)	480±.060 (12.19±1.52)	(1.4215 (36.106))	Ø394±.010 (10.01±0.25)	1.457 (37.01)	480±.060 (12.19±1.52)	(1.4215 (36.106))	NO	60 MM BORE, SLOT ON ARROW TAIL FLANGE.

F-Series ITB Outline (Do not use for construction)

Specifications

Power Supply	12/24 V systems (10–32 Vdc), reverse polarity protection
Power Consumption	24 W steady-state, 98 W instantaneous during transient
Travel	70 ±2 degrees
Torque	Steady State: 1.4 N·m (1.0 lb-ft) at 105 °C, 12 Vdc Transient: 2.7 N·m (2.0 lb-ft) at 105 °C, 12 Vdc
Mass/Weight	48 mm ITB = 4.9 kg (10.8 lb) 60 mm ITB = 4.7 kg (10.4 lb) 68 mm ITB = 4.5 kg (10.0 lb)
Command Input	PWM (4–32 V, 300–2000 Hz) or J1939 CAN (FSTP Only), Analog (FSTP Only) (4–20 mA or 0–5 Vdc)
Position Feedback Output	0.5 to 4.5 Vdc, configurable in software
Programming Port	Programmable with Service Tool software (9927-1419) and 14-pin harness 8923-1254 (FST) or 23-pin harness 8923-1255 (FSTP)
Performance	
Positioning Accuracy	±4% full stroke for all input types after effects from –40 to +85 °C board temperature ±7% full stroke all input types above 85 °C board temperature
10%–90% Step Slew Time	55 ms (at 12 Vdc, room temperature, no external load)
Bandwidth	>= 10 Hz at –3 db, ±0.5% of full scale >= 14 Hz at –3 db, ±2% of full scale
Environmental	
Ambient Operating Temp.	–40 to +105 °C (–40 to +221 °F)
ITB Flowing Medium Temp.	–40 to +105 °C (–40 to +221 °F)
Storage Temperature	–40 to +125 °C (–40 to +257 °F)
EMC	EN61000-6-2 (2005): Immunity for Industrial Environments EN61000-6-4 (2001): Emissions for Industrial Environments ISO 10605 (2001): ESD Immunity for Packaging and Handling, ±4 kV contact discharge ISO 11452-2,4: RF Immunity, 1 MHz – 2 GHz CISPR 25 (2002): Radiated RF Emissions, 30 MHz – 1 GHz, 2004/104/EC and ECE Regulation 10 limits ISO 7637-2 (2004): Conducted Transient Immunity, Pulse 1c, 2a, 3a, 3b, 4, and 5a
Humidity	US MIL-STD 810D, 507.2, Procedure III (60 °C, 95% RH); Lloyd's Register of Shipping Humidity Test 1; Det Norske Veritas Damp Heat per Woodward Procedure 4-04-6230
Chemical Resistance	SAE J1455, 4.4.3 (except water immersion testing)
Shock	40 G, 11 ms duration saw-tooth pulse per Woodward Procedure 3-04-6231, MS1
Vibration	Random: 0.3 G ² /Hz, 10–2000 Hz (22.1 Grms) 3 h/axis per Woodward Procedure 3-04-6231, RV3
Thermal Shock	SAE J1455, 4.1.3.2. Modified, –40 to +105 °C and 20 cycles
Ingress Protection	IP56 per IEC 60529, (dust ingress, water ingress) SAE J1455, sections 4.3, 4.4.3, 4.5, 4.7, 4.10.3.1
Regulatory Compliance	
CSA Certified	Class I, Division 2, Groups A, B, C, & D, T3 Type 3R Enclosure Rainproof
CE Marking	Stationary industrial markets only
EMC Directive	2004/108/EC
Other European Directives (non-CE marking):	
Machinery Directive	98/37/EC (compliant as a component)
Pressure Equipment Directive	97/23/EC (Exempt per Article 1-3.10)
Other International Compliance (vehicular markets only):	
UNECE	Regulations 67 and 110
Technical Manual	26355



PO Box 1519, Fort Collins CO, USA 80522-1519
1000 East Drake Road, Fort Collins CO 80525
Tel.: +1 (970) 482-5811 • Fax: +1 (970) 498-3058
www.woodward.com

Distributors & Service

Woodward has an international network of distributors and service facilities. For your nearest representative, call the Fort Collins plant or see the Worldwide Directory on our website.

This document is distributed for informational purposes only. It is not to be construed as creating or becoming part of any Woodward contractual or warranty obligation unless expressly stated in a written sales contract.

Copyright © Woodward 2007–2010, All Rights Reserved

For more information contact:



U.S. Toll Free 877-544-5201
Lada S/C Mexico 888-418-DRAK (3725)
www.drakecontrols.com